



Product Specification

G065VN01 V0

AU OPTRONICS CORPORATION

() Preliminary Specifications

(V) Final Specifications

Module	6.5 Inch Color TFT-LCD
Model Name	G065VN01 V0

Customer	Date
Checked & Approved by	
_____	_____

Note: This Specification is subject to change without notice.

Approved by	Date
<u>Peter ML Lee</u>	<u>2006/07/17</u>
Prepared by	
<u>Yen Chuang</u>	<u>2006/07/17</u>

General Display Business Division /
AU Optronics corporation

Contents

1. Handling Precautions4

2. General Description5

 2.1 Display Characteristics 5

 2.2 Optical Characteristics 6

3. Functional Block Diagram10

4. Absolute Maximum Ratings11

 4.1 Absolute Ratings of TFT LCD Module 11

 4.2 Absolute Ratings of Environment 11

5. Electrical Characteristics12

 5.1 TFT LCD Module 12

 5.2 Backlight Unit 14

6. Signal Characteristic15

 6.1 Pixel Format Image 15

 6.2 Scanning Direction 15

 6.3 The Input Data Format 16

 6.4 Signal Description 17

 6.5 Interface Timing 18

 6.6 Power ON/OFF Sequence 20

7. Connector & Pin Assignment21

 7.1 TFT LCD Module: LVDS Connector 21

 7.2 Backlight Unit: Lamp Connector 21

 7.3 Lamp Connector Pin Assignment 21

8. Reliability Test Criteria22

9. Mechanical Characteristics23

 9.1 LCM Outline Dimension (Front View) 23

 9.2 LCM Outline Dimension (Rear View) 24

 9.3 Screw Hole Depth and Center Position 26

10. Label27

 10.1 Shipping Label (on the rear side of TFT-LCD display) 27

 10.2 Carton Label (on the side of shipping carton) 27

 10.3 Carton Package 27

11 Safety28

 11.1 Sharp Edge Requirements 28

 11.2 Materials 28

 11.3 Capacitors 28

 11.4 National Test Lab Requirement 28



Record of Revision

Version and Date	Page	Old description	New Description	Remark
0.1 July 17, 2006	All	First edition final specifications to all customers		

1. Handling Precautions

- 1) Since front polarizer is easily damaged, please be cautious and not to scratch it.
- 2) Be sure to turn off power supply when inserting or disconnecting from input connector.
- 3) Wipe off water drop immediately. Long contact with water may cause discoloration or spots.
- 4) When the panel surface is soiled, wipe it with absorbent cotton or soft cloth.
- 5) Since the panel is made of glass, it may be broken or cracked if dropped or bumped on hard surface.
- 6) Since CMOS LSI is used in this module, take care of static electricity and insure human earth when handling.
- 7) Do not open nor modify the module assembly.
- 8) Do not press the reflector sheet at the back of the module to any direction.
- 9) In case if a module has to be put back into the packing container slot after it was taken out from the container, do not press the center of the CCFL Reflector edge. Instead, press at the far ends of the CFL Reflector edge softly. Otherwise the TFT Module may be damaged.
- 10) At the insertion or removal of the Signal Interface Connector, be sure not to rotate nor tilt the Interface Connector of the TFT Module.
- 11) After installation of the TFT Module into an enclosure (Notebook PC Bezel, for example), do not twist nor bend the TFT Module even momentary. At designing the enclosure, it should be taken into consideration that no bending/twisting forces are applied to the TFT Module from outside. Otherwise the TFT Module may be damaged.
- 12) Cold cathode fluorescent lamp in LCD contains a small amount of mercury. Please follow local ordinances or regulations for disposal.
- 13) Small amount of materials having no flammability grade is used in the LCD module. The LCD module should be supplied by power complied with requirements of Limited Power Source (IEC60950 or UL1950), or be applied exemption.
- 14) The LCD module is designed so that the CFL in it is supplied by Limited Current Circuit (IEC60950 or UL1950). Do not connect the CFL in Hazardous Voltage Circuit.

2. General Description

G065VN01 V0 is a Color Active Matrix Liquid Crystal Display composed of a TFT-LCD display, a driver circuit, and a backlight system. The screen format is intended to support VGA (640(H) x 480(V)) screen and 16.2M (RGB 8-bits) or 262k colors (RGB 6-bits). All input signals are LVDS interface compatible. Inverter card of backlight is not included.

G065VN01 V0 is designed for industrial display applications.

2.1 Display Characteristics

The following items are characteristics summary on the table under 25 °C condition:

Items	Unit	Specifications
Screen Diagonal	[inch]	6.5
Active Area	[mm]	132.48(H) x 99.36(V)
Pixels H x V		640x3(RGB) x 480
Pixel Pitch	[mm]	0.207 x 0.207
Pixel Arrangement		R.G.B. Vertical Stripe
Display Mode		TN, Normally White
Nominal Input Voltage VDD	[Volt]	3.3 typ.
Typical Power Consumption	[Watt]	4.26W (IRCFL=5.0mA) 3.56W (IRCFL=3.8mA) All black pattern
Weight	[Grams]	200g(typ.)
Physical Size	[mm]	153.0(H)x 118.0(V) x 10.7(D) (typ.)
Electrical Interface		1 channel LVDS
Surface Treatment		Anti-glare, Hardness 3H
Support Color		16.2M / 262K colors
Temperature Range		
Operating	[°C]	-10 to +70
Storage (Non-Operating)	[°C]	-20 to +80
RoHS Compliance		RoHS Compliance

2.2 Optical Characteristics

The optical characteristics are measured under stable conditions at 25°C (Room Temperature):

Item	Unit	Conditions	Min.	Typ.	Max.	Note
White Luminance	[cd/m ²]	IRCFL= 5.0mA (center point)	400	500	-	1
		IRCFL= 3.8mA (center point)	320	400	-	
Uniformity	%	5 Points	80	-	-	1, 2, 3, 4
		13 Points	60	-	-	
Contrast Ratio			300	600	-	5
Cross talk	%		-	-	4	6
Response Time	[msec]	Rising	-	15	20	7
	[msec]	Falling	-	10	15	
	[msec]	Raising + Falling	-	25	35	
Viewing Angle	[degree]	Horizontal (Right) CR = 10 (Left)	60	70	-	8
	[degree]		60	70	-	
	[degree]	Vertical (Upper) CR = 10 (Lower)	50	60	-	
	[degree]		50	60	-	
Color / Chromaticity Coordinates (CIE 1931)		Red x	0.590	0.620	0.650	
		Red y	0.320	0.350	0.380	
		Green x	0.275	0.305	0.335	
		Green y	0.550	0.580	0.610	
		Blue x	0.115	0.145	0.175	
		Blue y	0.085	0.115	0.145	
		White x	0.283	0.313	0.343	
		White y	0.299	0.329	0.359	
Color Gamut	%		50	55	-	

Note 1: Measurement method

Equipment Pattern Generator, Power Supply, Digital Voltmeter, Luminance meter (SR_3 or equivalent)

Aperture 1□with 50cm viewing distance

Test Point Center

Environment < 1 lux

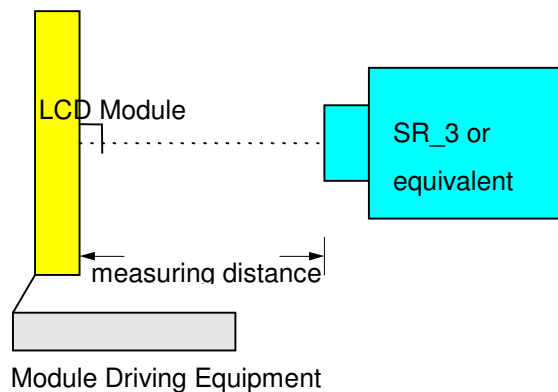

Note 2: Definition of 5 points position (Display active area : 132.48mm(W) x 99.36mm(H))

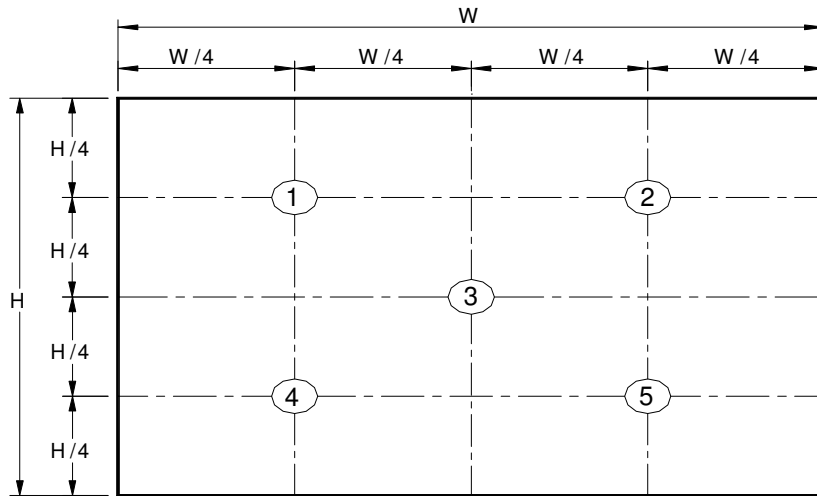

Note 3: Definition of 13 points position

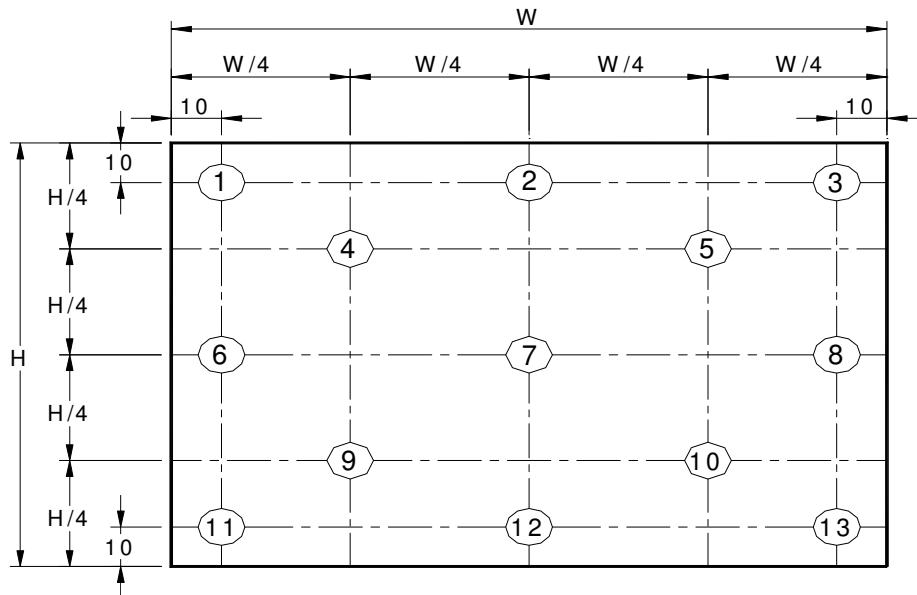

Note 4: The luminance uniformity of 5 and 13 points is defined by dividing the minimum luminance values by the maximum test point luminance

$$\delta_{W5} = \frac{\text{Minimum Brightness of five points}}{\text{Maximum Brightness of five points}}$$

$$\delta_{W13} = \frac{\text{Minimum Brightness of thirteen points}}{\text{Maximum Brightness of thirteen points}}$$

Note 5 : Definition of contrast ratio (CR):

$$\text{Contrast ratio (CR)} = \frac{\text{Brightness on the "White" state}}{\text{Brightness on the "Black" state}}$$

Note 6 : Definition of cross talk (CT)

$$CT = |Y_B - Y_A| / Y_A \times 100 (\%)$$

Where

Y_A = Luminance of measured location without gray level 0 pattern (cd/m²)

Y_B = Luminance of measured location with gray level 0 pattern (cd/m²)

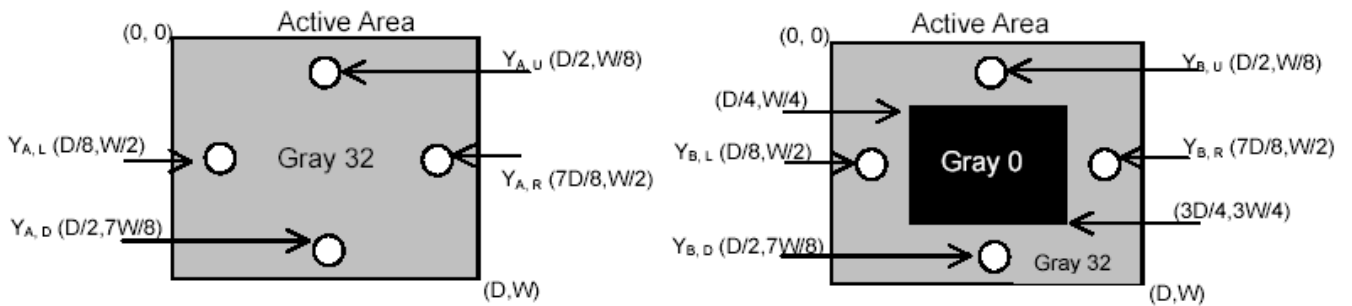

Note 7: Definition of response time:

The output signals of photo detector are measured when the input signals are changed from "White" to "Black" (falling time) and from "Black" to "White" (rising time), respectively. The response time interval is between 10% and 90% of amplitudes. Please refer to the figure as below.

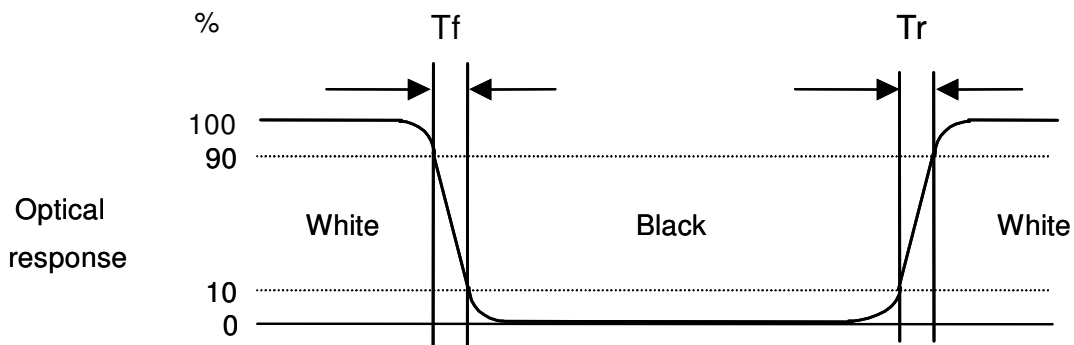

Note 8. Definition of viewing angle

Viewing angle is the measurement of contrast ratio ≥ 10 , at the screen center, over a 180° horizontal and 180° vertical range (off-normal viewing angles). The 180° viewing angle range is broken down as below: 90° (θ) horizontal left and right, and 90° (Φ) vertical high (up) and low (down). The measurement direction is typically perpendicular to the display surface with the screen rotated to its center to develop the desired measurement viewing angle.

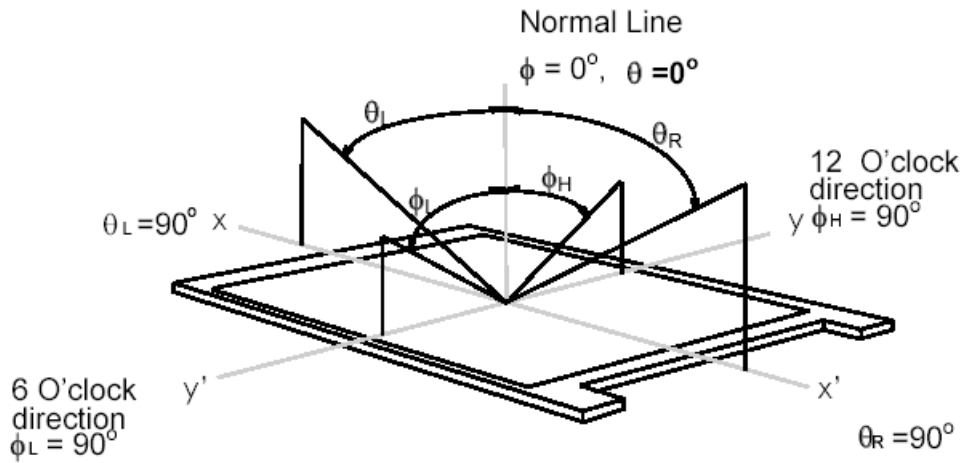

3. Functional Block Diagram

The following diagram shows the functional block of the 6.5 inch color TFT/LCD module:

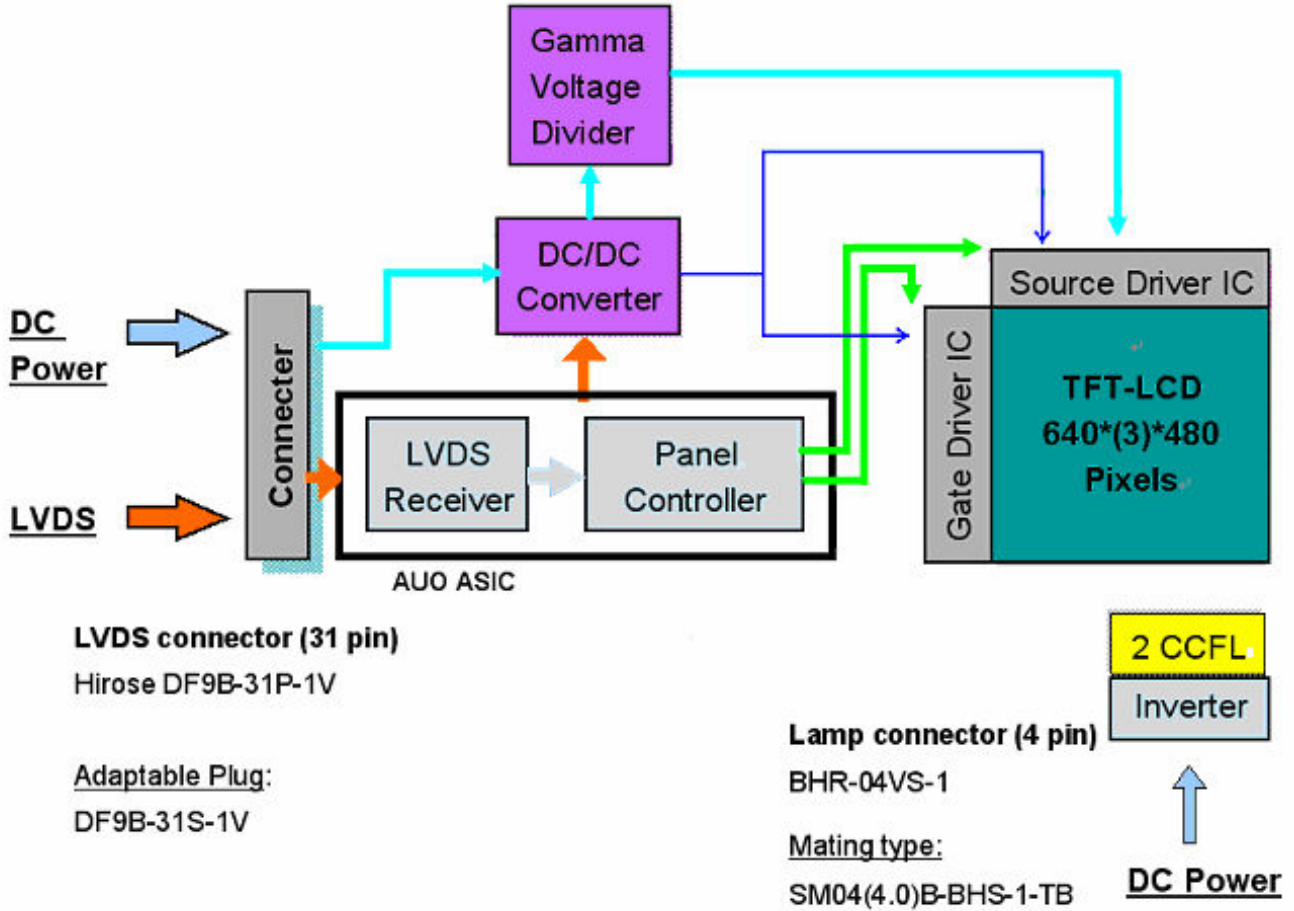

4. Absolute Maximum Ratings

4.1 Absolute Ratings of TFT LCD Module

Item	Symbol	Min	Max	Unit
Logic/LCD Drive Voltage	Vin	-0.3	+4.0	[Volt]

4.2 Absolute Ratings of Environment

Item	Symbol	Min	Max	Unit
Operating Temperature	TOP	-10	+70	[°C]
Operation Humidity	HOP	5	95	[%RH]
Storage Temperature	TST	-20	+80	[°C]
Storage Humidity	HST	5	95	[%RH]

Note: Maximum Wet-Bulb should be 39°C and no condensation.

5. Electrical Characteristics

5.1 TFT LCD Module

5.1.1 Power Specification

Symbol	Parameter	Min	Typ	Max	Units	Remark
VDD	Logic/LCD Drive Voltage	3.0	3.3	3.6	[Volt]	
IDD	VDD Current	-	185	-	[mA]	All Black Pattern (VDD=3.3V, at 60Hz)
Irush	LCD Inrush Current	-	-	1.5	[A]	Note 1
PDD	VDD Power	-	0.61	-	[Watt]	All Black Pattern (VDD=3.3V, at 60Hz)
VDDrp	Allowable Logic/LCD Drive Ripple Voltage	-	-	100	[mV] p-p	All Black Pattern (VDD=3.3V, at 60Hz)

Note 1: Measurement condition:

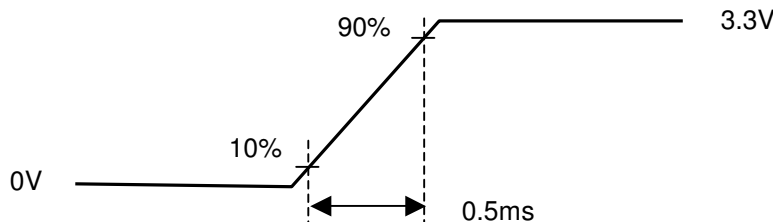
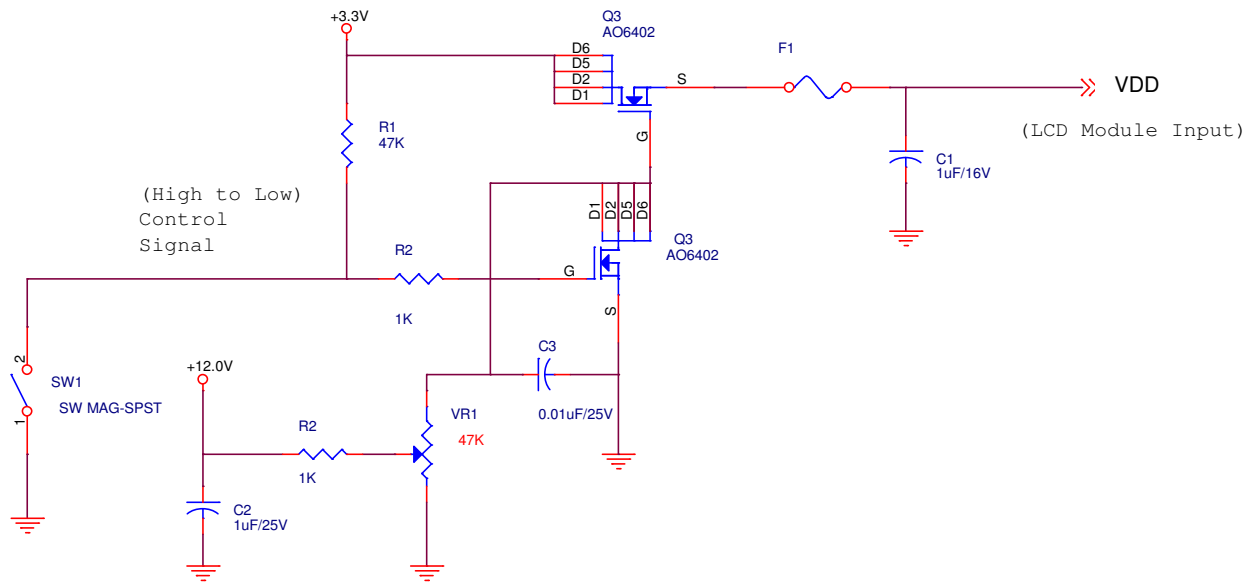

VDD rising time

5.1.2 Signal Electrical Characteristics

Input signals shall be low or Hi-Z state when VDD is off.

Symbol	Item	Min.	Typ.	Max.	Unit	Remark
VTH	Differential Input High Threshold	-	-	100	[mV]	VCM=1.25V
VTL	Differential Input Low Threshold	-100	-	-	[mV]	VCM=1.25V
VID	Input Differential Voltage	100	400	600	[mV]	
VICM	Differential Input Common Mode Voltage	1.1	-	1.45	[V]	VTH/VTL=+-100mV

LVDS Transmitter: THC63LVDM83A (THINE) or equivalent

Note: LVDS Signal Waveform.

Single-end Signal

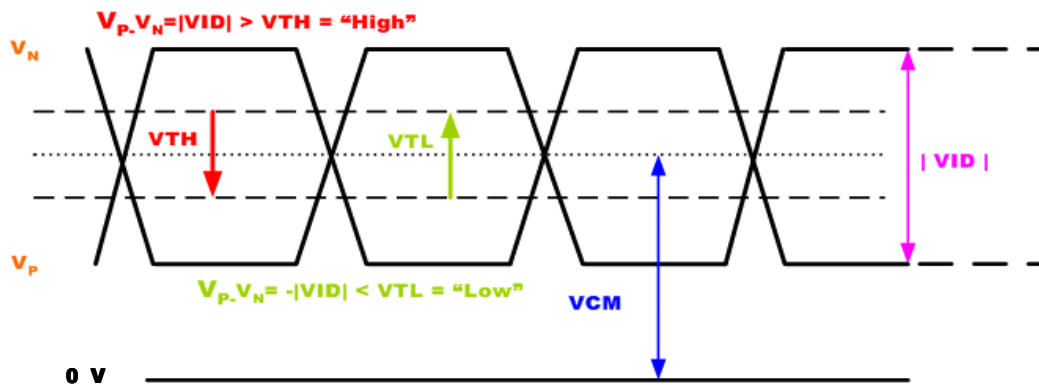

Differential Signal

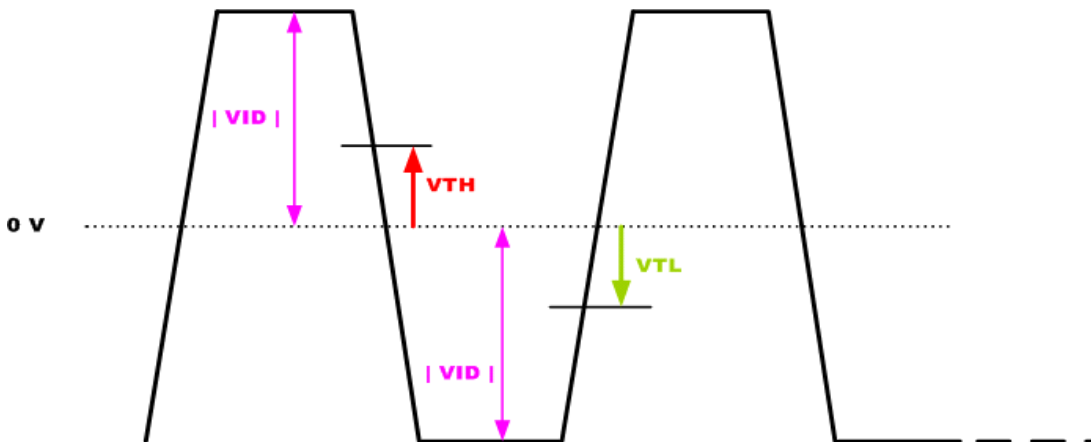

5.2 Backlight Unit

5.2.1 Parameter guideline for CCFL

Following characteristics are measured under a stable condition using an inverter at 25□ (Room Temperature):

Symbol	Parameter	Min.	Typ.	Max.	Unit	Remark
IRCFL	CCFL operation range	3.5	5	7	[mA] rms	(Ta=25°C) Note 1, 2
FCFL	CCFL Frequency	50	60	70	[KHz]	(Ta=25°C) Note 3
ViCFL (-10°C) (reference)	CCFL Ignition Voltage	-	-	1430	[Volt] rms	(Ta= -10°C)
ViCFL (25°C) (reference)	CCFL Ignition Voltage	-	-	650	[Volt] rms	(Ta=25°C)
VCFL	CCFL Discharge Voltage	-	365	-	[Volt] rms	(Ta=25°C) Note 4 IRCFL=5mA
		-	386	-		(Ta=25°C) Note 4 IRCFL=3.8mA
PCFL	CCFL Power consumption (inverter excluded)	-	3.65	-	[Watt]	(Ta=25°C) Note 4 IRCFL=5mA
		-	2.95	-		(Ta=25°C) Note 4 IRCFL=3.8mA
Lamp Life		50,000			Hrs	(Ta=25°C) Note 2 IRCFL = 5mA

Note 1: IRCFL is defined as the return current of an inverter. (In Figure. 1)

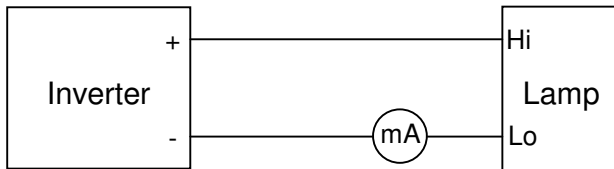

(Figure. 1: Measurement of return current)

A stable IRCFL is a current without flicker or biasing waveform provided by inverter that ensures the backlight perform to its specification. The ideal sine waveform should be symmetric in positive and negative polarities and the asymmetry rate of the inverter waveform should be below 10%.

It is recommended to use the inverter with detection circuit to avoid overvoltage, overcurrent, or mismatching waveform. The purpose is to avoid current flow into only one of the lamps when the other one is not in operation.

Note 2: The life time is defined as having expired when the brightness of the CCFL is reduced by its half. Different inverter designs will result in different input currents, different degrees of leakage, and therefore different impacts on lamp life. Concerning the leakage generated from the LCD panel and the inverter, lamp life is defined as IRCFL equals 5mA and the input current does not exceed 5.5mA

Note 3: CCFL frequency should be carefully determined to avoid interference between inverter and TFT LCD.

Note 4: Calculator value for reference (IRCFLxVCFLx2=PCFL).

Note 5: The display is with dual lamp design, and the CCFL current in above table refers to each lamp

6. Signal Characteristic

6.1 Pixel Format Image

Following figure shows the relationship between input signal and LCD pixel format.

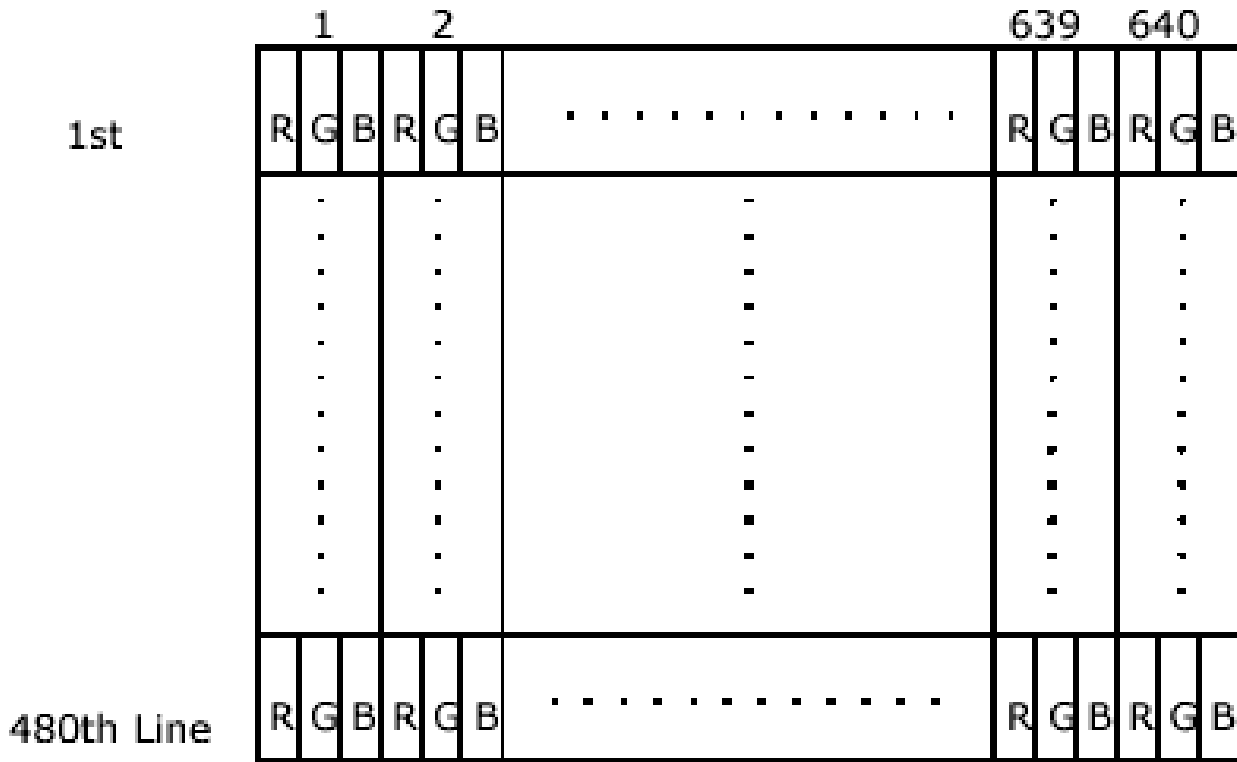

6.2 Scanning Direction

The following figures show the image seen from the front view. The arrow indicates the direction of scan.



Fig. 1 Normal scan (Pin8, DPS = Low or NC)

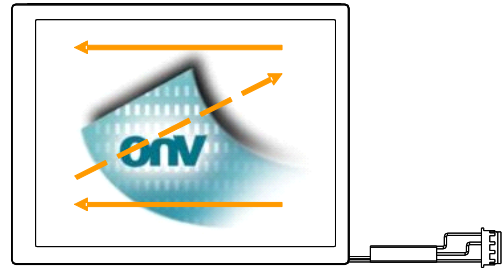
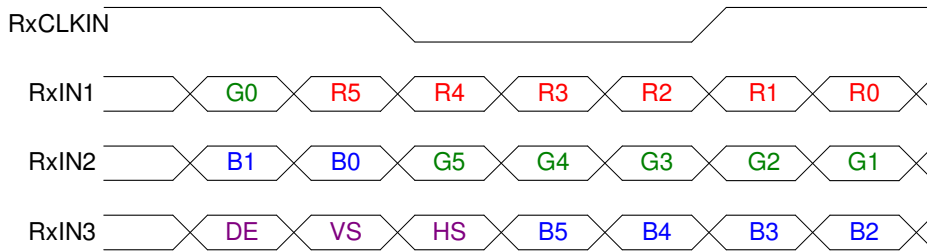

Fig. 2 Reverse scan (Pin8, DPS = High)

6.3 The Input Data Format

SEL68 = "High" or "NC" for 6 bits LVDS Input



SEL68 = "Low" for 8 bits LVDS Input

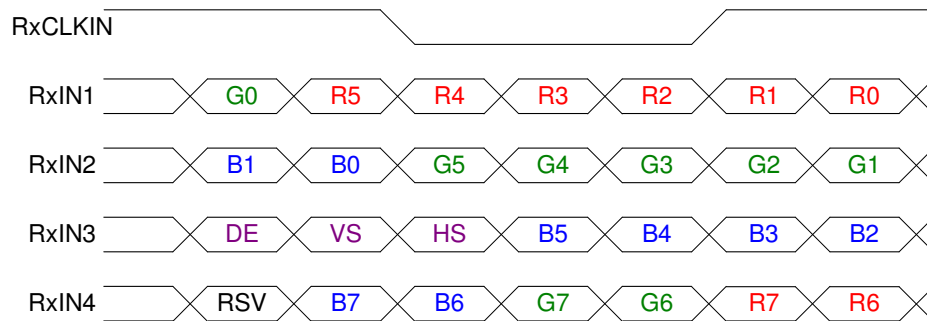

Signal Name	Description	Remark
R7	Red Data 7	Red-pixel Data For 8Bits LVDS input MSB: R7 ; LSB: R0 For 6Bits LVDS input MSB: R5 ; LSB: R0
R6	Red Data 6	
R5	Red Data 5	
R4	Red Data 4	
R3	Red Data 3	
R2	Red Data 2	
R1	Red Data 1	
R0	Red Data 0	
G7	Green Data 7	Green-pixel Data For 8Bits LVDS input MSB: G7 ; LSB: G0 For 6Bits LVDS input MSB: G5 ; LSB: G0
G6	Green Data 6	
G5	Green Data 5	
G4	Green Data 4	
G3	Green Data 3	
G2	Green Data 2	
G1	Green Data 1	
G0	Green Data 0	
B7	Blue Data 7	Blue-pixel Data For 8Bits LVDS input MSB: B7 ; LSB: B0 For 6Bits LVDS input MSB: B5 ; LSB: B0
B6	Blue Data 6	
B5	Blue Data 5	
B4	Blue Data 4	
B3	Blue Data 3	
B2	Blue Data 2	
B1	Blue Data 1	
B0	Blue Data 0	
RxCLKIN	LVDS Data Clock	
DE	Data Enable Signal	When the signal is high, the pixel data shall be valid to be displayed.
VS	Vertical Synchronous Signal	
HS	Horizontal Synchronous Signal	

Note: Output signals from any system shall be low or Hi-Z state when VDD is off.

6.4 Signal Description

The module uses a LVDS receiver embedded in AUO's ASIC. LVDS is a differential signal technology for LCD interface and a high-speed data transfer device.

Pin No.	Symbol	Pin Description
1	GND	Ground
2	GND	Ground
3	RxIN4+	LVDS differential input (Red 6-Red 7, Green 6-Green 7, Blue 6-Blue 7, RSV) NC for 6bit LVDS input.
4	NC	No connection
5	RxIN4-	LVDS differential input (Red 6-Red 7, Green 6-Green 7, Blue 6-Blue 7, RSV) NC for 6bit LVDS input.
6	NC	No connection
7	GND	Ground
8	DPS	Selection of scan direction DPS = "Low" or "NC", normal scan. DPS = "High", reverse scan.
9	RxCLKIN+	LVDS differential clock input
10	NC	No connection
11	RxCLKIN-	LVDS differential clock input
12	NC	No connection
13	GND	Ground
14	GND	Ground
15	RxIN3+	LVDS differential input(Blue2-Blue5, Hsync, Vsync, DE)
16	GND	Ground
17	RxIN3-	LVDS differential input(Blue2-Blue5, Hsync, Vsync, DE)
18	NC	No connection
19	GND	Ground
20	NC	No connection
21	RxIN2+	LVDS differential input(Green1-Green5, Blue0-Blue1)
22	NC	No connection
23	RxIN2-	LVDS differential input(Green1-Green5, Blue0-Blue1)
24	NC	No connection
25	GND	Ground
26	SEL68	Selection for either 6bit or 8bit LVDS input: SEL68 = "High" or "NC", accepts 6bit LVDS data input; SEL68 = "Low", accepts 8bit LVDS data input.
27	RxIN1+	LVDS differential input(Red0-Red5, Green0)
28	VCC	Power supply
29	RxIN1-	LVDS differential input(Red0-Red5, Green0)
30	VCC	Power supply
31	GND	Ground

Note 1: Input signals shall be in low status when VDD is off.

Note 2: NC = No Connection

6.5 Interface Timing

6.5.1 Timing Characteristics

Signal	Parameter		Symbol	Min.	Typ.	Max.	Unit	Remark
Clock Timing	Clock frequency		$1/T_{\text{Clock}}$	20	25.2	50	MHz	Note1, 2
Vsync Timing	Vertical Section	Period	T_V	520	525	622	T_{Line}	Note1, 2
		Active	T_{VD}	480	480	480		
		Blanking	T_{VB}	40	45	142		
Hsync Timing	Horizontal Section	Period	T_H	770	800	1070	T_{Clock}	Note1, 2
		Active	T_{HD}	640	640	640		
		Blanking	T_{HB}	130	160	430		

Note 1: Frame rate is 60 Hz.

Note 2: DE mode.

6.5.2 LVDS Signal PIN Assignment

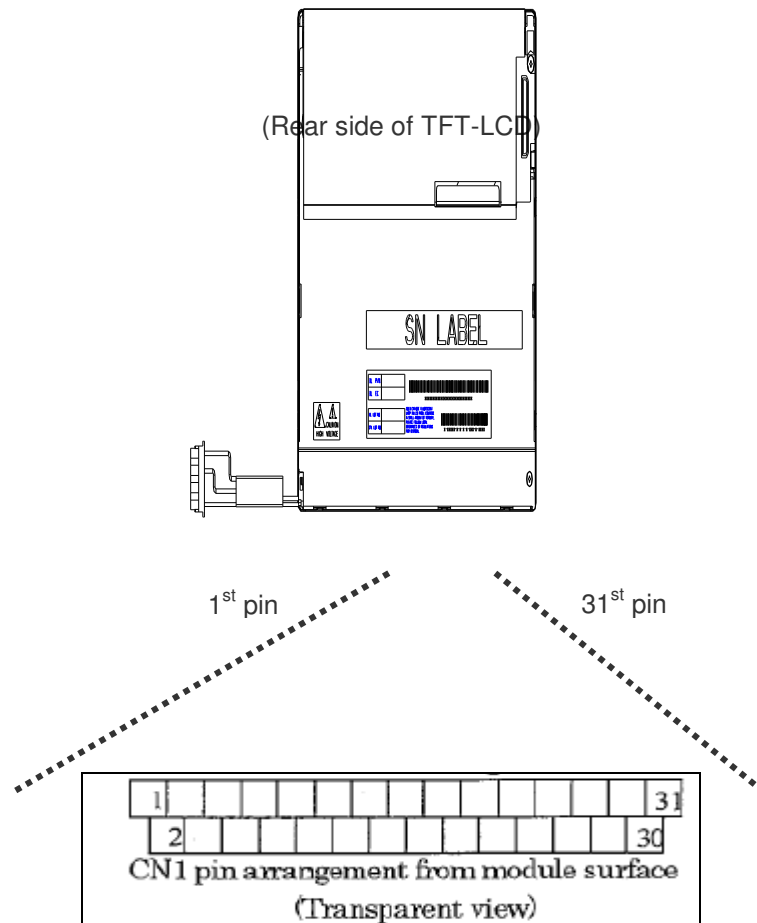

6.5.3 Input Timing Diagram

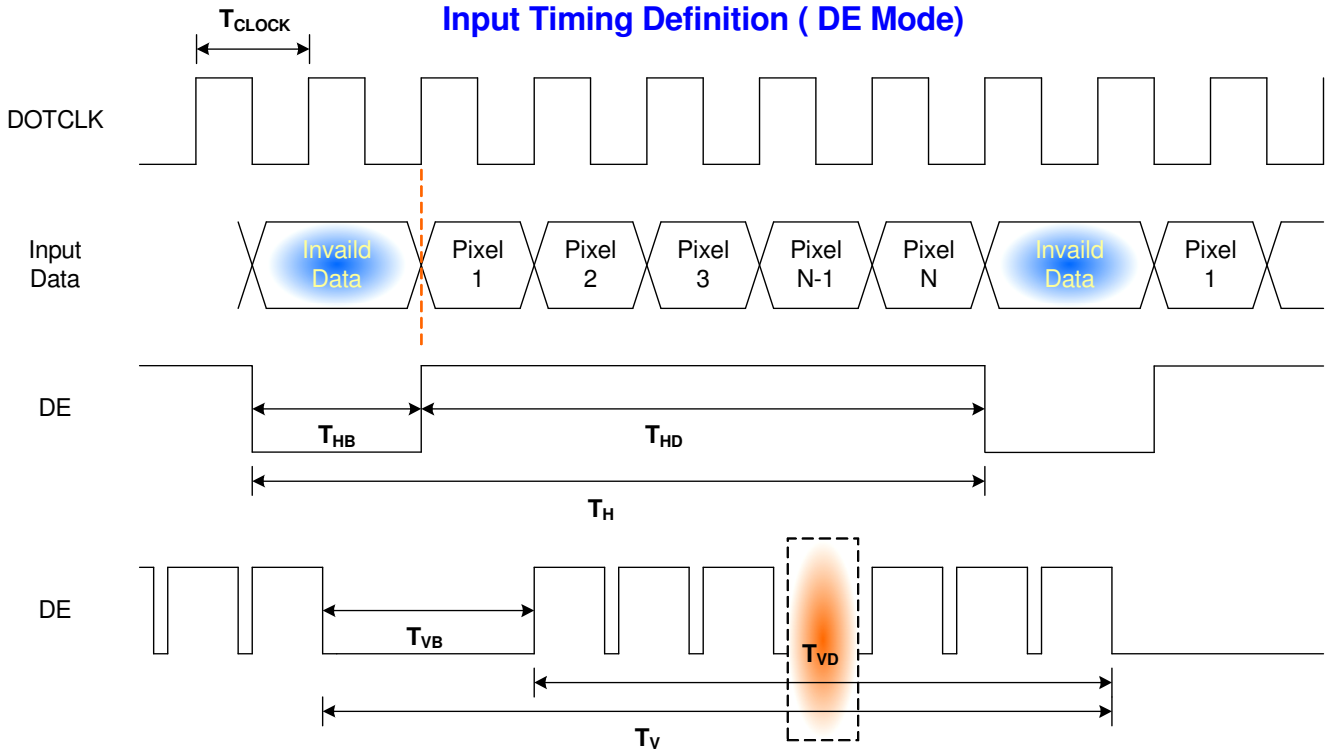

6.6 Power ON/OFF Sequence

VDD power and lamp on/off sequence is as below. Interface signals are also shown in the chart. Signals from any system shall be Hi-Z state or low level when VDD is off.

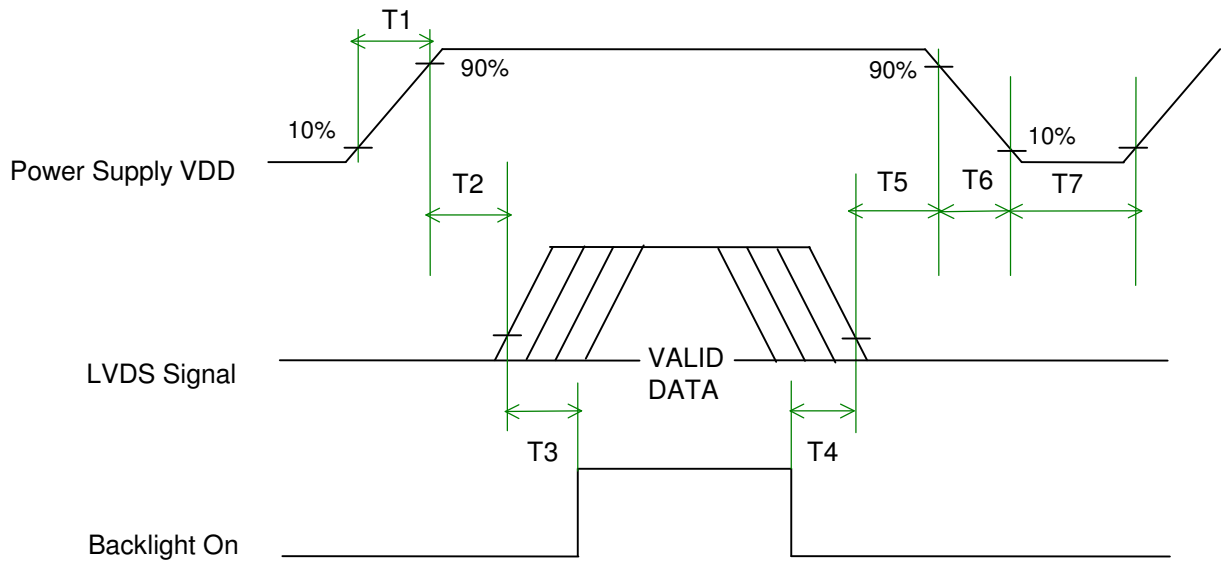

Power ON/OFF sequence timing

Parameter	Value			Units
	Min.	Typ.	Max.	
T1	0.5	-	10	ms
T2	0	-	50	ms
T3	180	-	-	ms
T4	180	-	-	ms
T5	0	-	50	ms
T6	0	-	10	ms
T7	500	-	-	ms

The above on/off sequence should be applied to avoid abnormal function in the display. Please make sure to turn off the power when you plug the cable into the input connector or pull the cable out of the connector.

7. Connector & Pin Assignment

Physical interface is described as for the connector on module. These connectors are capable of accommodating the following signals and will be following components.

7.1 TFT LCD Module: LVDS Connector

Connector Name / Designation	Signal Connector
Manufacturer	Hirose or compatible
Connector Model Number	DF9B-31P-1V or compatible
Adaptable Plug	DF9B-31S-1V or compatible

7.2 Backlight Unit: Lamp Connector

Connector Name / Designation	Lamp Connector
Manufacturer	JST or compatible
Connector Model Number	BHR-04VS-1 or compatible
Mating Model Number	SM04(4.0)B-BHS-1-TB or compatible

7.3 Lamp Connector Pin Assignment

Pin #	Cable color	Signal Name
4	White	Lamp Low Voltage
3	NC	No Connection
2	Pink	Lamp High Voltage
1	Pink	Lamp High Voltage

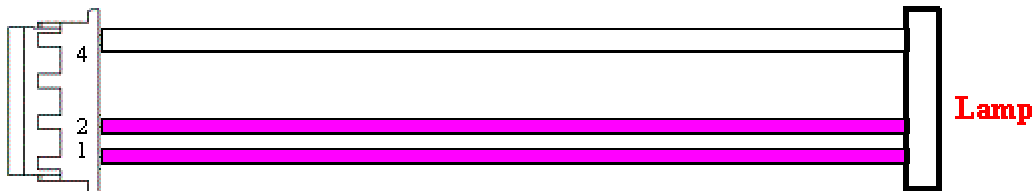

8. Reliability Test Criteria

Items	Required Condition	Note
Temperature Humidity Bias	40□/90%,300Hr	
High Temperature Operation	70□,300Hr	
Low Temperature Operation	-10□,300Hr	
Hot Storage	80□,300 hours	
Cold Storage	-20□,300 hours	
Thermal Shock Test	-20□/30 min ,60□/30 min ,100cycles	
Hot Start Test	70□/1 Hr min. power on/off per 5 minutes, 5 times	
Cold Start Test	-10□/1 Hr min. power on/off per 5 minutes, 5 times	
Shock Test (Non-Operating)	50G,11ms,Half-sine wave,(+X,+Y,+Z)	
Vibration Test (Non-Operating)	1.5G, 50~500~50Hz, Sine wave 30mins/axis, 3 direction (X, Y, Z)	
ESD	Contact : ± 8KV/ operation, Class B Air : ± 15KV / operation, Class B	Note 1
Attitude Test	Operating: 14,000 ft, Ramp: 2000 ft/min, 8hrs Non-operating: 40,000 ft, Ramp: 2000 ft/min, 24hrs	

Note1: According to EN61000-4-2 , ESD class B: Some performance degradation allowed. No data lost

- . Self-recoverable. No hardware failures.

9. Mechanical Characteristics

9.1 LCM Outline Dimension (Front View)

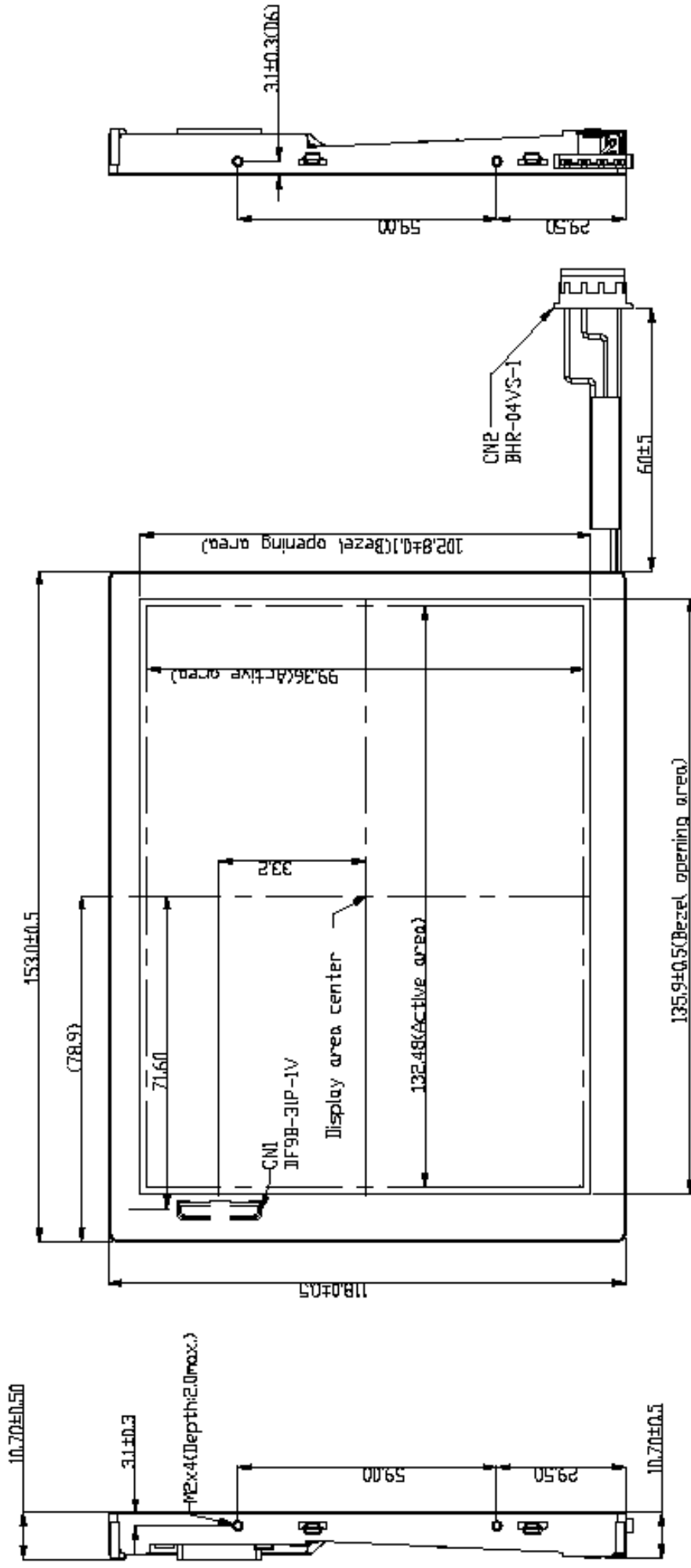

9.2 LCM Outline Dimension (Rear View)

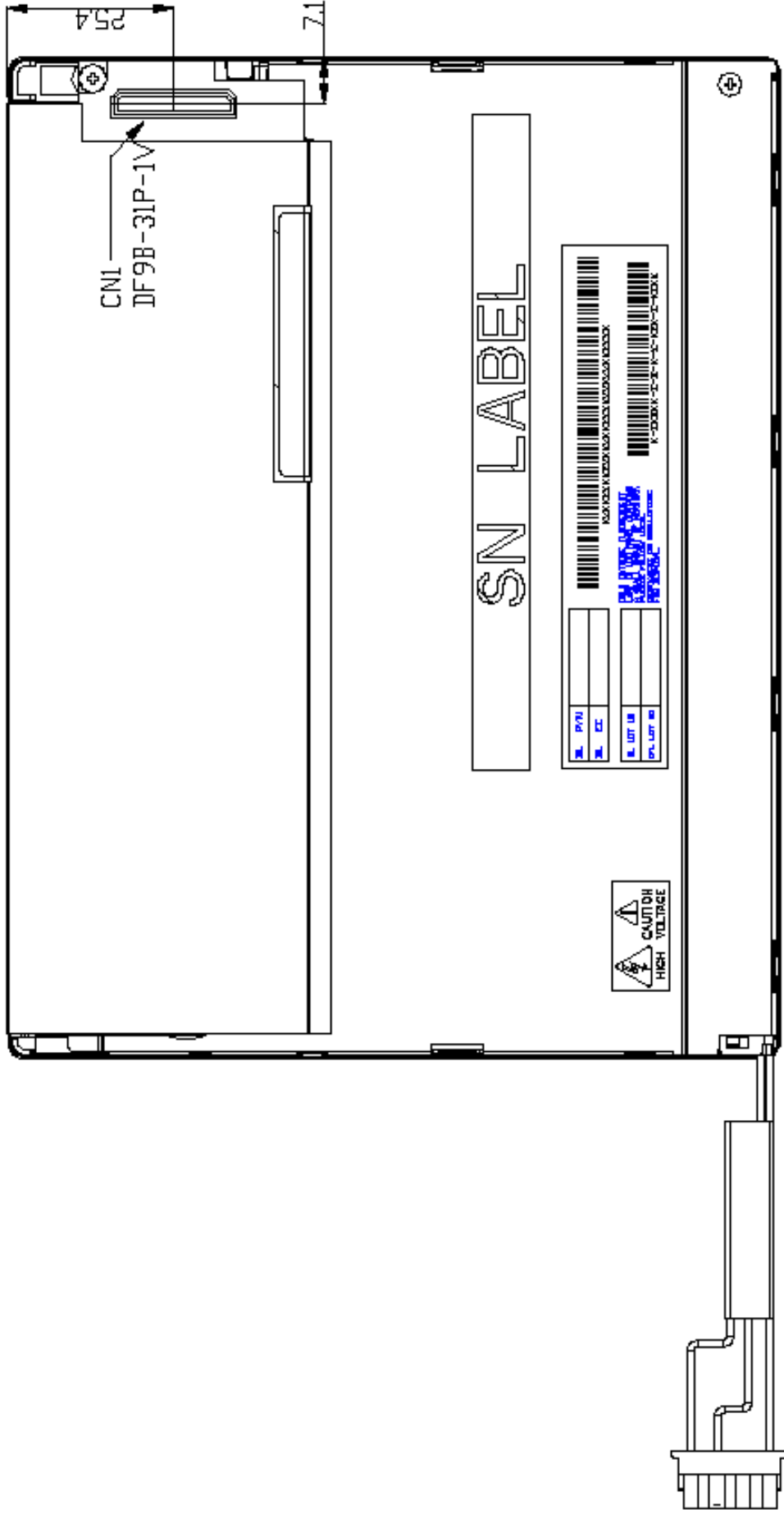



Product Specification

AU OPTRONICS CORPORATION

G065VN01 V0

9.2 LCM Outline Dimension (Rear View)

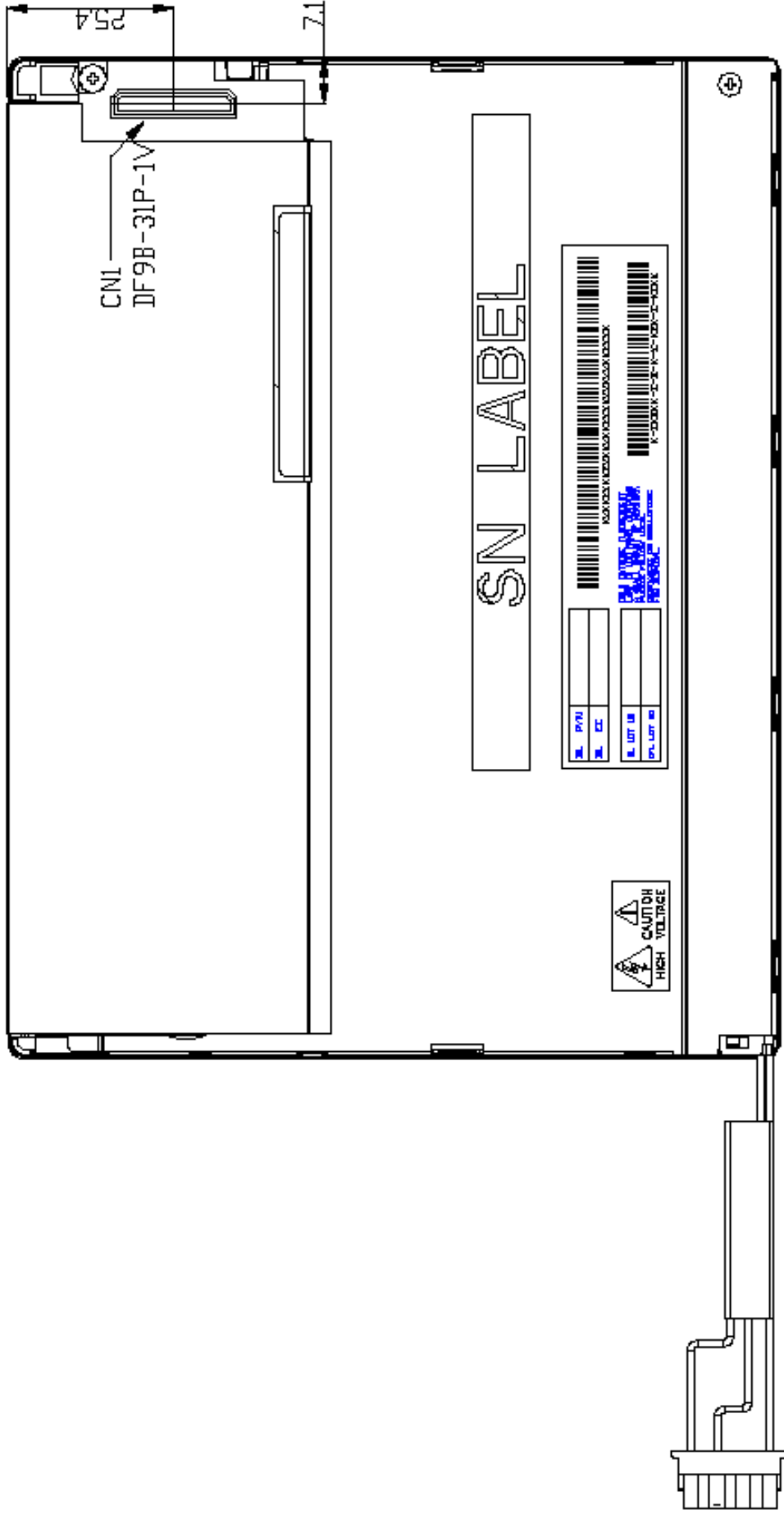

10. Label

10.1 Shipping Label (on the rear side of TFT-LCD display)

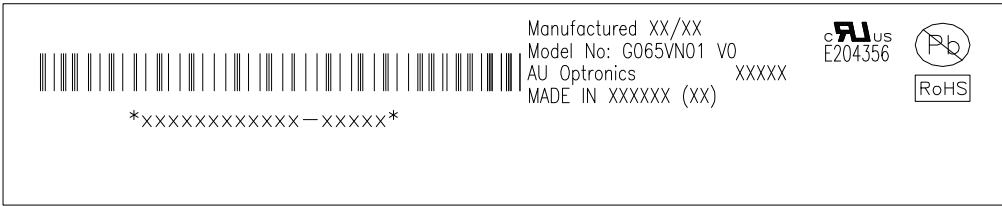

10.2 Carton Label (on the side of shipping carton)

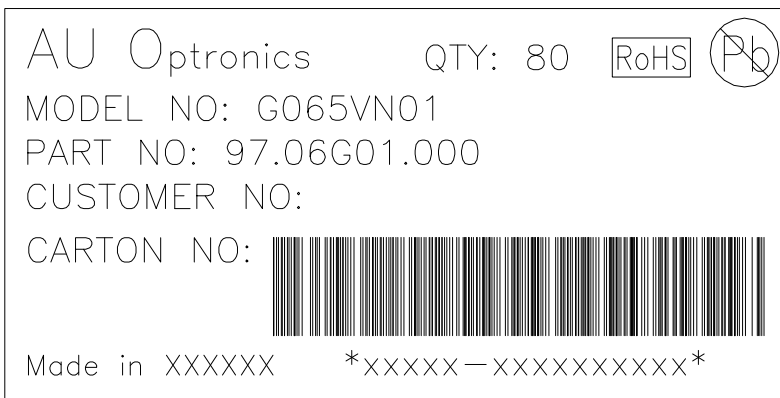

10.3 Carton Package

Max capacity: 80 TFT-LCD module per carton (40pcs * 2 layers)

Max weight: 19 kg per carton

Outside dimension of carton: 425(L)mm* 386(W)mm* 430(H)mm



11 Safety

11.1 Sharp Edge Requirements

There will be no sharp edges or comers on the display assembly that could cause injury.

11.2 Materials

11.2.1 Toxicity

There will be no carcinogenic materials used anywhere in the display module. If toxic materials are used, they will be reviewed and approved by the responsible AUO toxicologist.

11.2.2 Flammability

All components including electrical components that do not meet the flammability grade UL94-V1 in the module will complete the flammability rating exception approval process.

The printed circuit board will be made from material rated 94-V1 or better. The actual UL flammability rating will be printed on the printed circuit board.

11.3 Capacitors

If any polarized capacitors are used in the display assembly, provisions will be made to keep them from being inserted backwards.

11.4 National Test Lab Requirement

The display module will satisfy all requirements for compliance to:

UL 60950

U.S.A. Information Technology Equipment